

## 2660 Series

### Double Groove O-Belt Pulley Tapered Sleeve Roller

#### Products Features

- Based on the 2260 Series, covered with grey polypropylene taper sleeve; abrasion resistant, low noise, shockproof.
- In the case of sensitive to static electricity, you can choose anti-static tapered sleeve (black), surface resistance value:  $10^6 \sim 10^9 \Omega$ .
- The O-belt pulley is located on the head end of the roller which separates the drive area and the conveying area avoiding interference between the O-belt and the conveyed goods.
- The bearing end cap consists of a precision ball bearing, a polymer housing and end cap seal. Combined they provide an attractive, smooth and quite running roller.
- The design of the end cap protects the bearings by providing excellent resistance to dust and splashed water.
- Because there is no grooving on the tube, the tube will not have any distortion and the roller will run more smoothly.
- The duty capacity of the roller depends on the drive capacity of the O-belt. The weight of single items to be conveyed should not exceed 30kg.
- Temperature range:  $-5^\circ\text{C} \sim 40^\circ\text{C}$ .

Please contact us if humidity out of this scope.

#### Specifications

Bearing Unit	
Bearing housing	Polyamide, black
End cap	Polypropylene, Damon green
Precision ball bearing	6002
Drive Element	
O-belt pulley	Polyamide, black

## 2660 Series Curve Conveyor Roller

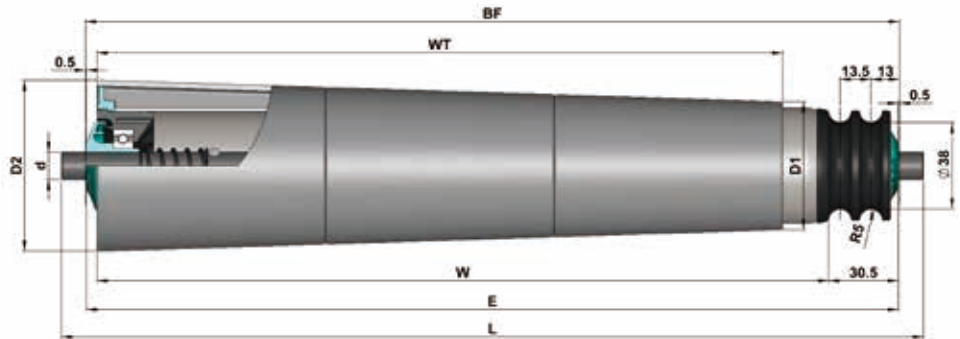

## 2660 Series Spring Loaded

Tube Dia.(D)	Shaft Dia.(d)			
Φ50	Φ12/11hex	BF=W+36	E=W+35	L=W+57

Tube	D*T	WT	D1	D2	Shaft Dia.(d)	
					11hex	Φ12
Steel, zinc plated, tapered sleeve	Φ50x1.5	295	Φ52.5	Φ71	2.660.SHJ.AFA	2.660.SHJ.ACA
		345	Φ55.6	Φ77.3		
		395	Φ52.5	Φ77.3		
		445	Φ55.6	Φ83.6		
		495	Φ52.5	Φ83.6		
		545	Φ55.6	Φ89.9		
Steel, zinc plated, tapered sleeve <b>(Static conductive version,black )</b>	Φ50x1.5	595	Φ52.5	Φ89.9	2.660.SHK.AFA	2.660.SHK.ACA
		645	Φ55.6	Φ96.2		
		695	Φ52.5	Φ96.2		
		745	Φ55.6	Φ102.5		
		795	Φ52.5	Φ102.5		
		845	Φ55.6	Φ108.8		
		895	Φ52.5	Φ108.8		

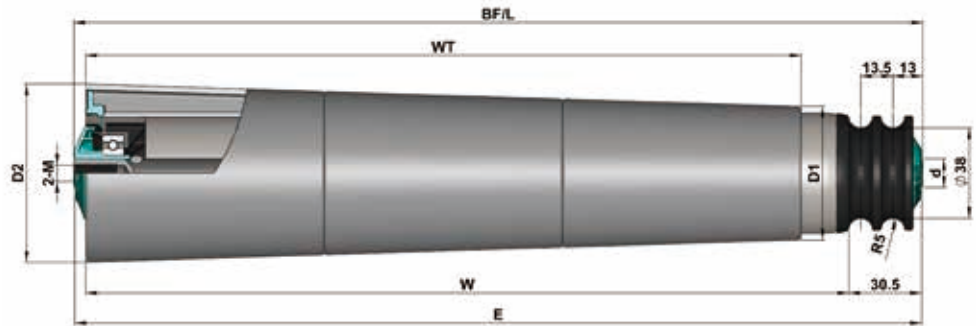

## 2660 Series Internal Thread

Tube Dia.(D)	Shaft Dia.(d)			
Φ50	Φ12/15	BF=W+36	E=W+35	L=W+36

Tube	D*T	WT	D1	D2	Shaft Dia.(d)	
					Φ12 ( M8x15 )	Φ15 ( M10x20 )
Steel, zinc plated, tapered sleeve	Φ50x1.5	295	Φ52.5	Φ71	2.660.SHJ.ACC	2.660.SHJ.ADC
		345	Φ55.6	Φ77.3		
		395	Φ52.5	Φ77.3		
		445	Φ55.6	Φ83.6		
		495	Φ52.5	Φ83.6		
		545	Φ55.6	Φ89.9		
Steel, zinc plated, tapered sleeve <b>(Static conductive version,black )</b>	Φ50x1.5	595	Φ52.5	Φ89.9	2.660.SHK.ACC	2.660.SHK.ADC
		645	Φ55.6	Φ96.2		
		695	Φ52.5	Φ96.2		
		745	Φ55.6	Φ102.5		
		795	Φ52.5	Φ102.5		
		845	Φ55.6	Φ108.8		
		895	Φ52.5	Φ108.8		