

2311/2321 Series Driven Conveyor Roller



2311/2321 Series

Steel Single/Double Sprocket Roller

Product Features

- Welding the steel sprocket to the steel tube gives it the capacity to transmit high torque and meet the requirements for heavy duty transportation.
- The precision ball bearing is pressed tightly into the steel bearing housing for maximum durability.
- The environmental working conditions are broad. They can be used in both high and low temperature applications.
- The covering on the outside of the sprocket protects the bearings by providing excellent resistance to dust and splashed water.
- Temperature range: -20°C ~ +80°C.

Specifications

Bearing Unit	
Bearing housing	Steel, zinc plated
Precision ball bearing	6001/6002/6202/6204
Ground sleeve	Polyamide, black

Driving element	
Sprocket	Steel, zinc plated
	Steel black (when the tube is stainless steel or hard chrome plated)



2311/2321 Series Load Capacity

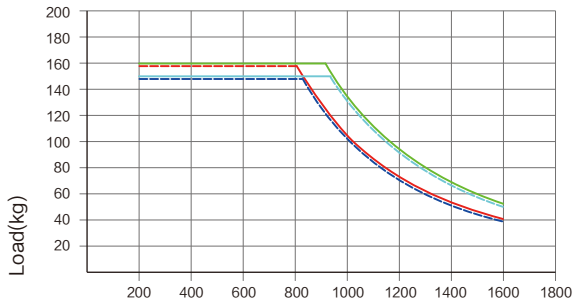

Length(mm)

- Steel tube $\Phi 50 \times 2.0$, shaft $\Phi 15$, internal thread
- Steel tube $\Phi 50 \times 1.5$, shaft $\Phi 15$, internal thread
- Steel tube $\Phi 50 \times 2.0$, shaft $\Phi 12$, internal thread
- Steel tube $\Phi 50 \times 1.5$, shaft $\Phi 12$, internal thread

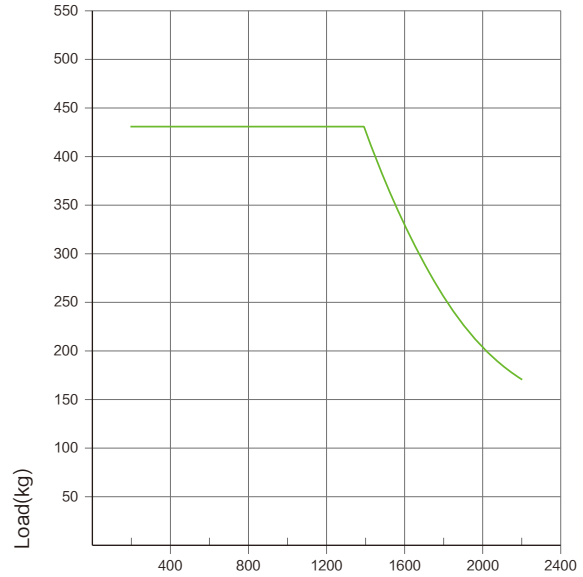

Length(mm)

- Steel tube $\Phi 80 \times 3.0$, shaft $\Phi 20$, internal thread

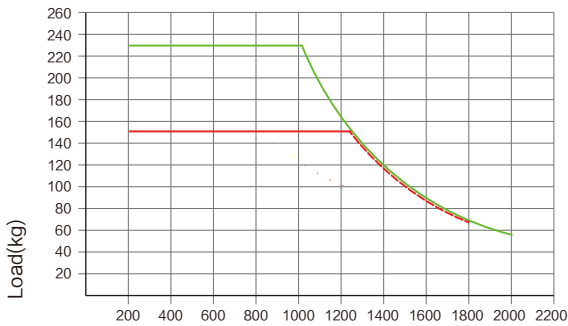

Length(mm)

- Steel tube $\Phi 60 \times 2.0$, shaft $\Phi 15$, internal thread
- Steel tube $\Phi 60 \times 2.0$, shaft $\Phi 12$, internal thread

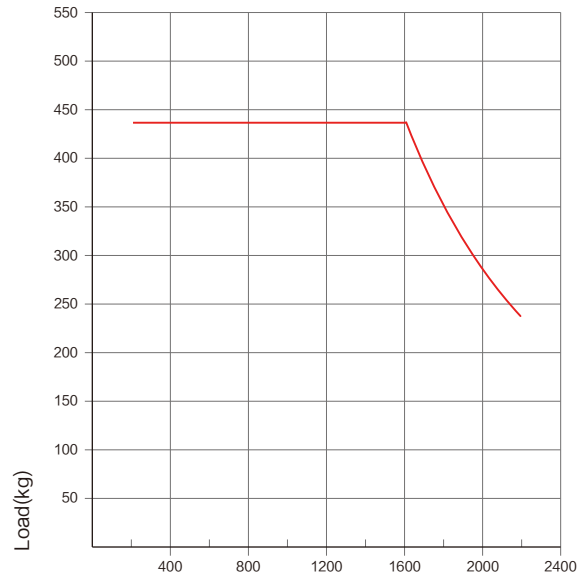

Length(mm)

- Steel tube $\Phi 89 \times 3.0$, shaft $\Phi 20$, internal thread

⚠ Above data shows the static load capacity of the roller for a uniformly distributed load.
 You should also consider the chain tension, motor power drive factors, calculation based on the smallest value.

2311/2321 Series Driven Conveyor Roller

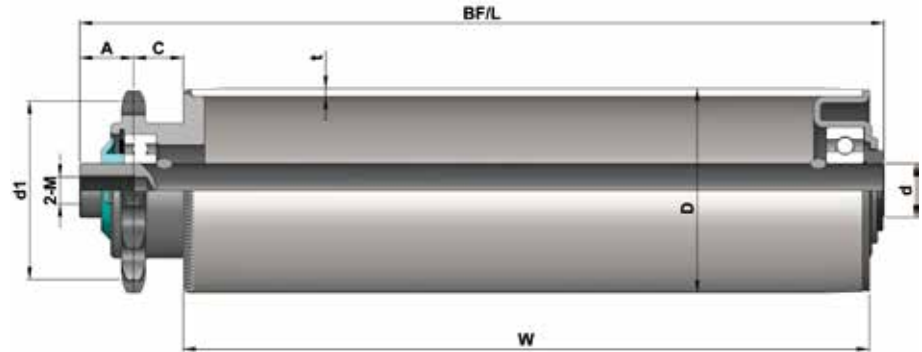

2311 Series Internal Thread

Tube Dia.(D)	Shaft Dia.(d)		Spocket style	A	C	d1
Φ50	Φ12	BF/L=W+40	08B11T	17	18.5	Φ45.08
Φ50	Φ15	BF/L=W+41	08B14T	17	18.5	Φ57.07
Φ60	Φ12/15	BF/L=W+41	08B14T	17	18.5	Φ57.07
Φ80	Φ20	BF/L=W+44	10B15T	20	18.5	Φ76.35
Φ89	Φ20	BF/L=W+44	10B15T	20	18.5	Φ76.35

Tube	D*T	Shaft Dia.(d)		
		Φ12 (M8x15)	Φ15 (M10x20)	Φ20 (M12x25)
Steel, zinc plated	Φ50x1.5	2.311.JHA.ACC	○	
	Φ50x2.0	2.311.JWA.ACC	○	
	Φ60x2.0	2.311.JOA.ACC	2.311.JOA.ADC	
	Φ60x3.0		2.311.JLA.ADC	
	Φ80x3.0			2.311.J6A.AEC
	Φ89x3.0			2.311.JYA.AEC
Steel, zinc plated with steel flange	Φ60x3.0		2.311.JLG.ADC	
	Φ80x3.0			2.311.J6G.AEC
	Φ89x3.0			2.311.JYG.AEC
Stainless steel	Φ50x1.5	2.311.NHC.BCC	○	
	Φ60x2.0	2.311.NOC.BCC	2.311.NOC.BDC	

○—Available configuration

⚙️ Φ50、60mm rollers can be fitted with PVC sleeve (2mm).

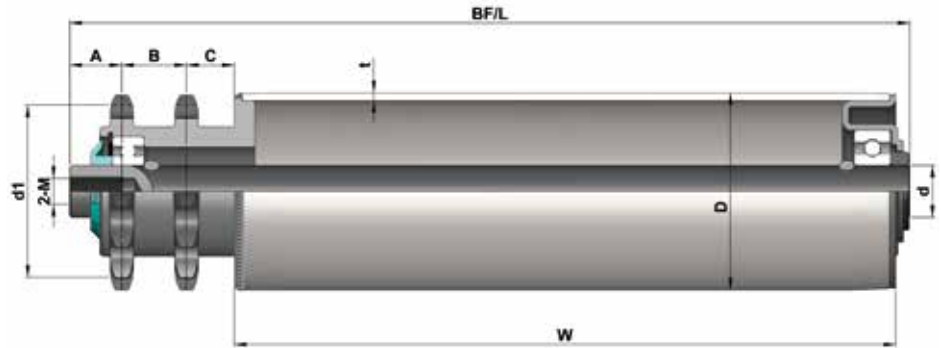

2321 Series Internal Thread

Tube Dia.(D)	Shaft Dia.(d)		Spocket style	A	B	C	d1
Φ50	Φ12	BF/L=W+62	08B11T	17	22	18.5	Φ45.08
Φ50	Φ15	BF/L=W+63	08B14T	17	22	18.5	Φ57.07
Φ60	Φ12/15	BF/L=W+63	08B14T	17	22	18.5	Φ57.07
Φ80	Φ20	BF/L=W+69	10B15T	20	25	18.5	Φ76.35
Φ89	Φ20	BF/L=W+69	10B15T	20	25	18.5	Φ76.35

Tube	D*T	Shaft Dia.(d)		
		Φ12 (M8x15)	Φ15 (M10x20)	Φ20 (M12x25)
Steel, zinc plated	Φ50x1.5	2.321.JHA.ACC	○	
	Φ50x2.0	2.321.JWA.ACC	○	
	Φ60x2.0	2.321.JOA.ACC	2.321.JOA.ADC	
	Φ60x3.0		2.321.JLA.ADC	
	Φ80x3.0			2.321.J6A.AEC
Steel, zinc plated with steel flange	Φ89x3.0			2.321.JYA.AEC
	Φ60x3.0		2.321.JLG.ADC	
	Φ80x3.0			2.321.J6G.AEC
Stainless steel	Φ89x3.0			2.321.JYG.AEC
	Φ50x1.5	2.321.NHC.BCC	○	
	Φ60x2.0	2.321.NOC.BCC	2.321.NOC.BDC	

○—Available configuration

⚙️ Φ50、60mm rollers can be fitted with PVC sleeve (2mm).

2311/2321 Series Driven Conveyor Roller

Steel Flange

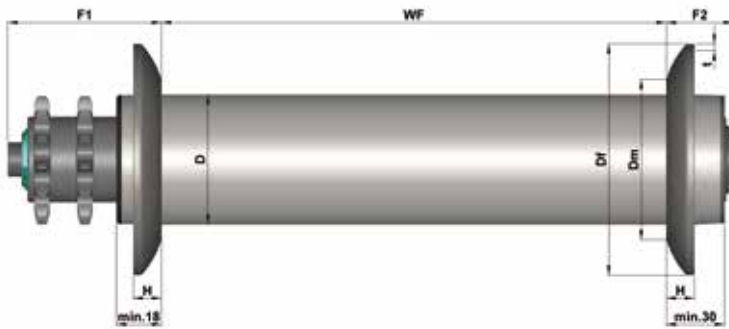

Unit: mm

D	Df	Dm	H	t
Φ60	Φ120	Φ80	12	3
Φ80	Φ150	Φ110	18	4
Φ89	Φ150	Φ110	18	4

1. Steel flange and tube are welded together making it strong and durable.
2. Steel tube only.

Stainless steel Flange(304)

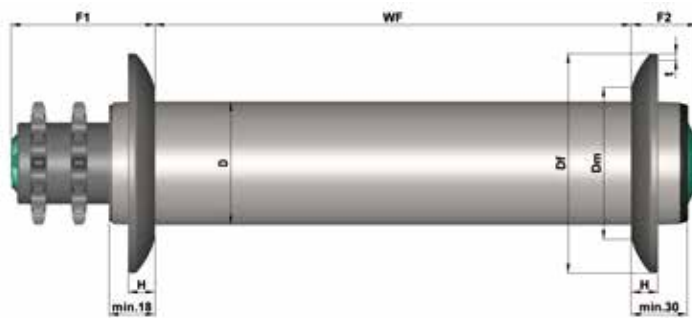

Unit: mm

D	Df	Dm	H	t
Φ60	Φ120	Φ80	12	3

1. Stainless Steel flange and tube are welded together making it strong and durable.
2. Stainless Steel tube only.