

2230/2240 Series Driven Conveyor Roller



2230/2240 Series Single/Double Grooved Conveyor Roller

Product Features

- Compared with chain drive, the O-belt drive has the advantages of low noise and high speed. It is widely used for light/medium duty carton conveying.
- The bearing end cap consists of a precision ball bearing, a polymer housing and end cap seal. Combined they provide an attractive, smooth and quite running roller.
- The design of the end cap protects the bearings by providing excellent resistance to dust and splashed water.
- The position of the grooves can be customized.
- Anti-static design.(only effective when rolling)
- Temperature range: -5°C ~ +40°C.
- Humidity available \geq 30%

Please contact us if humidity out of this scope.

Specifications

Bearing Unit	
Bearing housing	Polyamide,black
End cap	Polypropylene, Damon green
Precision ball bearing	6002



About duty

1. Duty is the maximum conveying capacity of driven roller (it is not roller's maximum load capacity) For more information about the load capacity, refer to the load capacity of 1200 series dia 50 roller on Page 27.
2. In driven conveying, duty plays a decisive role.
3. The duty capacity of the rollers depend on the drive method and drive capacity of the O-belt.
single goods should not over 30 kg.

Single Grooved Drive

1. The driving force for each roller is transmitted separately from the line shaft. It has a higher duty capacity in comparison to the double groove drive. Ideally suited for long conveyors. The maximum conveying length of each unit can be over 10 meters.
2. When used in curve conveyors, the line shaft is connected by universal joint couplings.
3. Maintenance is relatively difficult as you need to disassemble the entire line shaft.

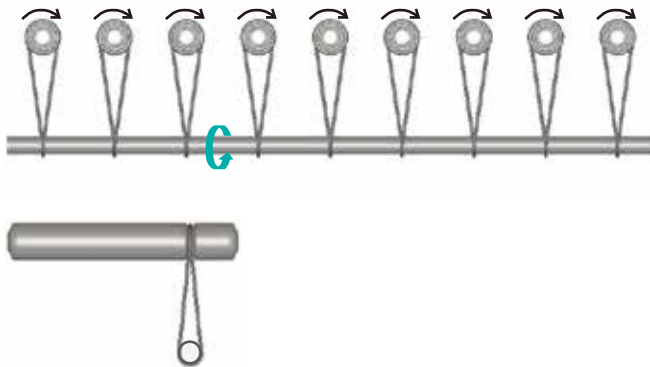

Single Grooved Drive Layout :

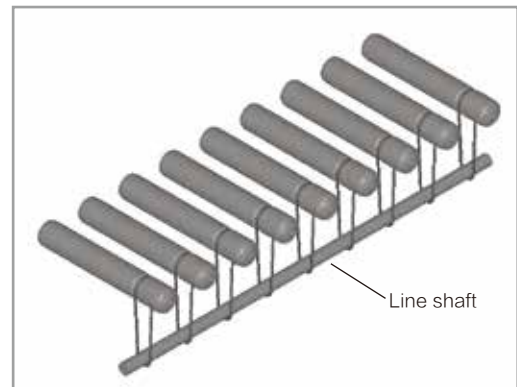

Double Grooved Drive

1. Simple arrangement. Easy installation and maintenance.
2. The driving torque deteriorates rapidly from roller to roller. Typically single MDR can only drive 7 to 8 rollers.
The weight of single items to be conveyed should not exceed 30kg.
3. The preloading value is required for the length of O-belt loop. It may vary according to the different O-belt suppliers. Please check the specifications with the O-belt supplier. Typically, reduce the preloading value by 5% – 8% from the theoretical length of loop.

Double Grooved Drive Layout :



2230/2240 Series Driven Conveyor Roller

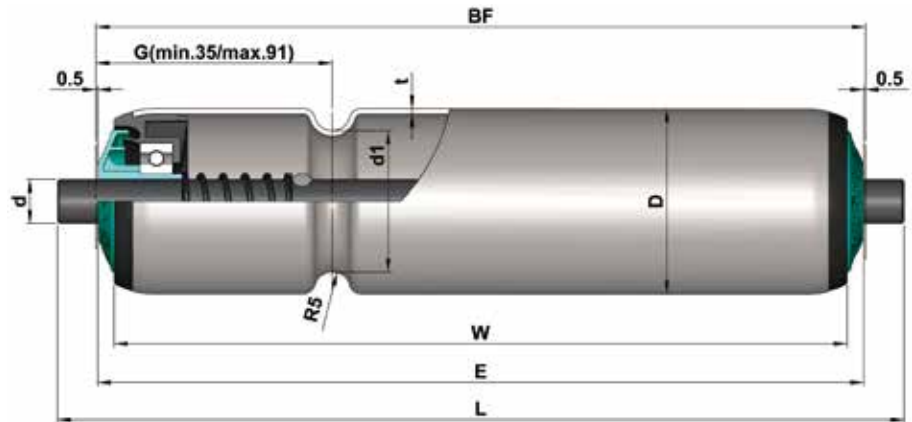

2230 Series Spring Loaded

Tube Dia.(D)	Shaft Dia.(d)				G	d1
Φ40	Φ8/10/12/11hex	BF=W+10	E=W+9	L=W+31	65	Φ30
Φ50	Φ8/10/12/11hex	BF=W+10	E=W+9	L=W+31	65	Φ38.5
Φ60	Φ10/12/11hex	BF=W+10	E=W+9	L=W+31	65	Φ48.0

Tube	D*T	Shaft Dia.(d)			
		Φ8	Φ10	11hex	Φ12
Steel, zinc plated	Φ40x1.5	○	2.230.SEC.AMA	2.230.SEC.BFA	2.230.SEC.ACA
	Φ50x1.5	○	2.230.SHC.AMA	2.230.SHC.BFA	2.230.SHC.ACA
	Φ60x2.0		○	2.230.SOC.BFA	2.230.SOC.ACA
Steel, zinc plated with PVC sleeve (2mm)	Φ50x1.5	○	2.230.SHD.AMA	2.230.SHD.BFA	2.230.SHD.ACA
Stainless steel	Φ50x1.5	○	2.230.NHC.BMA	2.230.NHC.BFA	2.230.NHC.BCA
	Φ60x2.0		○	2.230.NOC.BFA	2.230.NOC.BCA

○—Available configuration

⚙️ Φ40/60mm rollers can be fitted with PVC sleeve (2mm).

⚙️ Φ50mm rollers can be fitted with PU sleeve (2mm).

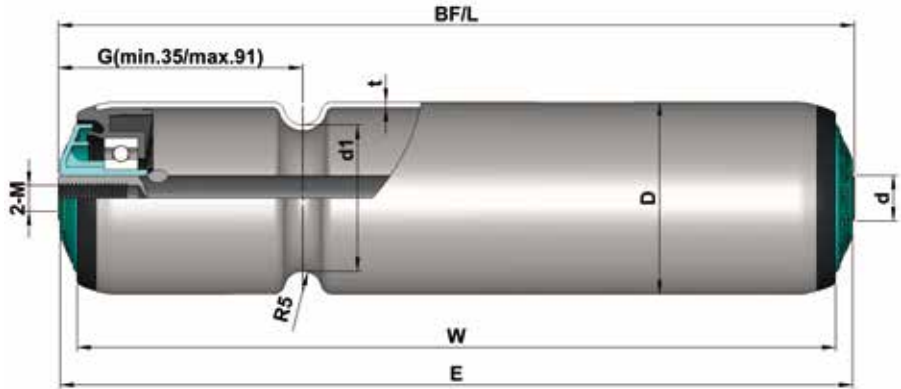

2230 Series Internal Thread

Tube Dia.(D)	Shaft Dia.(d)				G	d1
Φ40	Φ12	BF=W+10	E=W+9	L=W+10	65	Φ30
Φ50	Φ12/15	BF=W+10	E=W+9	L=W+10	65	Φ38.5
Φ60	Φ12/15	BF=W+10	E=W+9	L=W+10	65	Φ48.0

Tube	D*T	Shaft Dia.(d)	
		Φ12 (M8x15)	Φ15 (M10x20)
Steel, zinc plated	Φ40x1.5	2.230.SEC.ACC	
	Φ50x1.5	2.230.SHC.ACC	2.230.SHC.ADC
	Φ60x2.0	2.230.SOC.ACC	2.230.SOC.ADC
Steel, zinc plated with PVC sleeve (2mm)	Φ50x1.5	2.230.SHD.ACC	2.230.SHD.ADC
Stainless steel	Φ50x1.5	2.230.NHC.BCC	2.230.NHC.BDC
	Φ60x2.0	2.230.NOC.BCC	2.230.NOC.BDC

⚙️ Φ40/60mm rollers can be fitted with PVC sleeve (2mm).

⚙️ Φ50mm rollers can be fitted with PU sleeve (2mm).

2230/2240 Series Driven Conveyor Roller

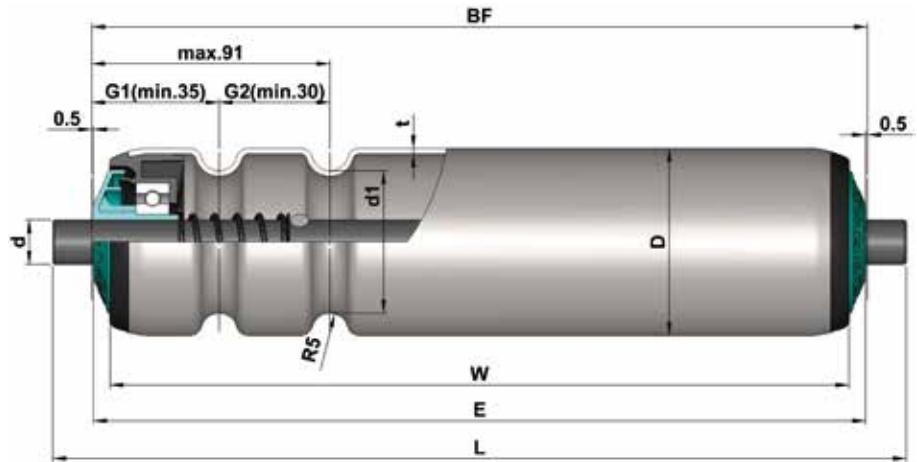

2240 Series Spring Loaded

Tube Dia.(D)	Shaft Dia.(d)				G1	G2	d1
Φ40	Φ8/10/12/11hex	BF=W+10	E=W+9	L=W+31	35	30	Φ30
Φ50	Φ8/10/12/11hex	BF=W+10	E=W+9	L=W+31	35	30	Φ38.5
Φ60	Φ10/12/11hex	BF=W+10	E=W+9	L=W+31	35	30	Φ48.0

Tube	D*T	Shaft Dia.(d)			
		Φ8	Φ10	11hex	Φ12
Steel, zinc plated	Φ40x1.5	○	2.240.SEC.AMA	2.240.SEC.BFA	2.240.SEC.ACA
	Φ50x1.5	○	2.240.SHC.AMA	2.240.SHC.BFA	2.240.SHC.ACA
	Φ60x2.0		○	2.240.SOC.BFA	2.240.SOC.ACA
Steel, zinc plated with PVC sleeve (2mm)	Φ50x1.5	○	2.240.SHD.AMA	2.240.SHD.BFA	2.240.SHD.ACA
Stainless steel	Φ50x1.5	○	2.240.NHC.BMA	2.240.NHC.BFA	2.240.NHC.BCA
	Φ60x2.0		○	2.240.NOC.BFA	2.240.NOC.BCA

○—Available configuration

⚙️ Φ40/60mm rollers can be fitted with PVC sleeve (2mm).

⚙️ Φ50mm rollers can be fitted with PU sleeve (2mm).

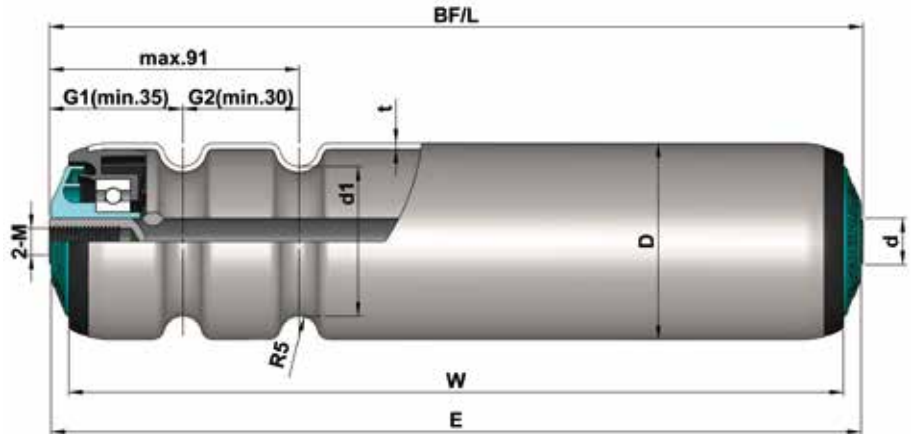

2240 Series **Internal Thread**

Tube Dia.(D)	Shaft Dia.(d)				G1	G2	d1
Φ40	Φ12/15	BF=W+10	E=W+9	L=W+10	35	30	Φ30
Φ50	Φ12/15	BF=W+10	E=W+9	L=W+10	35	30	Φ38.5
Φ60	Φ12/15	BF=W+10	E=W+9	L=W+10	35	30	Φ48.0

Tube	D*T	Shaft Dia.(d)	
		Φ12 (M8x15)	Φ15 (M10x20)
Steel, zinc plated	Φ40x1.5	2.240.SEC.ACC	
	Φ50x1.5	2.240.SHC.ACC	2.240.SHC.ADC
	Φ60x2.0	2.240.SOC.ACC	2.240.SOC.ADC
Steel, zinc plated with PVC sleeve (2mm)	Φ50x1.5	2.240.SHD.ACC	2.240.SHD.ADC
Stainless steel	Φ50x1.5	2.240.NHC.BCC	2.240.NHC.BDC
	Φ60x2.0	2.240.NOC.BCC	2.240.NOC.BDC

⚙️ Φ40/60mm rollers can be fitted with PVC sleeve (2mm).

⚙️ Φ50mm rollers can be fitted with PU sleeve (2mm).